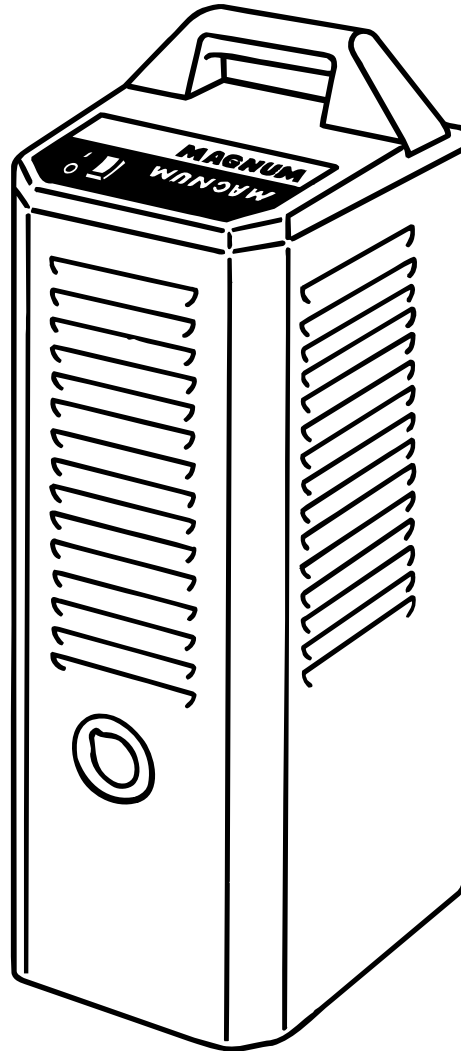

MAGNUM™ COOLERS 10-I AND 20-I March, 1999

For use with machines having Code Number 9743, 9745, 9984, 9986, 10266 and 10268

Safety Depends on You

Lincoln arc welding and cutting equipment is designed and built with safety in mind. However, your overall safety can be increased by proper installation ... and thoughtful operation on your part. **DO NOT INSTALL, OPERATE OR REPAIR THIS EQUIPMENT WITHOUT READING THIS MANUAL AND THE SAFETY PRECAUTIONS CONTAINED THROUGHOUT.** And, most importantly, think before you act and be careful.

**OPERATOR'S MANUAL**

World's Leader in Welding and Cutting Products



Premier Manufacturer of Industrial Motors

• Sales and Service through Subsidiaries and Distributors Worldwide •

Cleveland, Ohio 44117-1199 U.S.A. TEL: 216.481.8100 FAX: 216.486.1751 WEB SITE: www.lincolnelectric.com

⚠ WARNING



CALIFORNIA PROPOSITION 65 WARNINGS



Diesel engine exhaust and some of its constituents are known to the State of California to cause cancer, birth defects, and other reproductive harm.

The Above For Diesel Engines

The engine exhaust from this product contains chemicals known to the State of California to cause cancer, birth defects, or other reproductive harm.

The Above For Gasoline Engines

ARC WELDING CAN BE HAZARDOUS. PROTECT YOURSELF AND OTHERS FROM POSSIBLE SERIOUS INJURY OR DEATH. KEEP CHILDREN AWAY. PACEMAKER WEARERS SHOULD CONSULT WITH THEIR DOCTOR BEFORE OPERATING.

Read and understand the following safety highlights. For additional safety information, it is strongly recommended that you purchase a copy of "Safety in Welding & Cutting - ANSI Standard Z49.1" from the American Welding Society, P.O. Box 351040, Miami, Florida 33135 or CSA Standard W117.2-1974. A Free copy of "Arc Welding Safety" booklet E205 is available from the Lincoln Electric Company, 22801 St. Clair Avenue, Cleveland, Ohio 44117-1199.

BE SURE THAT ALL INSTALLATION, OPERATION, MAINTENANCE AND REPAIR PROCEDURES ARE PERFORMED ONLY BY QUALIFIED INDIVIDUALS.



FOR ENGINE powered equipment.

1.a. Turn the engine off before troubleshooting and maintenance work unless the maintenance work requires it to be running.



1.b. Operate engines in open, well-ventilated areas or vent the engine exhaust fumes outdoors.



1.c. Do not add the fuel near an open flame welding arc or when the engine is running. Stop the engine and allow it to cool before refueling to prevent spilled fuel from vaporizing on contact with hot engine parts and igniting. Do not spill fuel when filling tank. If fuel is spilled, wipe it up and do not start engine until fumes have been eliminated.



1.d. Keep all equipment safety guards, covers and devices in position and in good repair. Keep hands, hair, clothing and tools away from V-belts, gears, fans and all other moving parts when starting, operating or repairing equipment.

1.e. In some cases it may be necessary to remove safety guards to perform required maintenance. Remove guards only when necessary and replace them when the maintenance requiring their removal is complete. Always use the greatest care when working near moving parts.

1.f. Do not put your hands near the engine fan. Do not attempt to override the governor or idler by pushing on the throttle control rods while the engine is running.

1.g. To prevent accidentally starting gasoline engines while turning the engine or welding generator during maintenance work, disconnect the spark plug wires, distributor cap or magneto wire as appropriate.



1.h. To avoid scalding, do not remove the radiator pressure cap when the engine is hot.



ELECTRIC AND MAGNETIC FIELDS may be dangerous

2.a. Electric current flowing through any conductor causes localized Electric and Magnetic Fields (EMF). Welding current creates EMF fields around welding cables and welding machines

2.b. EMF fields may interfere with some pacemakers, and welders having a pacemaker should consult their physician before welding.

2.c. Exposure to EMF fields in welding may have other health effects which are now not known.

2.d. All welders should use the following procedures in order to minimize exposure to EMF fields from the welding circuit:

2.d.1. Route the electrode and work cables together - Secure them with tape when possible.

2.d.2. Never coil the electrode lead around your body.

2.d.3. Do not place your body between the electrode and work cables. If the electrode cable is on your right side, the work cable should also be on your right side.

2.d.4. Connect the work cable to the workpiece as close as possible to the area being welded.

2.d.5. Do not work next to welding power source.

Mar '95



ELECTRIC SHOCK can kill.

- 3.a. The electrode and work (or ground) circuits are electrically "hot" when the welder is on. Do not touch these "hot" parts with your bare skin or wet clothing. Wear dry, hole-free gloves to insulate hands.
- 3.b. Insulate yourself from work and ground using dry insulation. Make certain the insulation is large enough to cover your full area of physical contact with work and ground.
- In addition to the normal safety precautions, if welding must be performed under electrically hazardous conditions (in damp locations or while wearing wet clothing; on metal structures such as floors, gratings or scaffolds; when in cramped positions such as sitting, kneeling or lying, if there is a high risk of unavoidable or accidental contact with the workpiece or ground) use the following equipment:**
- Semiautomatic DC Constant Voltage (Wire) Welder.
 - DC Manual (Stick) Welder.
 - AC Welder with Reduced Voltage Control.
- 3.c. In semiautomatic or automatic wire welding, the electrode, electrode reel, welding head, nozzle or semiautomatic welding gun are also electrically "hot".
- 3.d. Always be sure the work cable makes a good electrical connection with the metal being welded. The connection should be as close as possible to the area being welded.
- 3.e. Ground the work or metal to be welded to a good electrical (earth) ground.
- 3.f. Maintain the electrode holder, work clamp, welding cable and welding machine in good, safe operating condition. Replace damaged insulation.
- 3.g. Never dip the electrode in water for cooling.
- 3.h. Never simultaneously touch electrically "hot" parts of electrode holders connected to two welders because voltage between the two can be the total of the open circuit voltage of both welders.
- 3.i. When working above floor level, use a safety belt to protect yourself from a fall should you get a shock.
- 3.j. Also see Items 6.c. and 8.



ARC RAYS can burn.

- 4.a. Use a shield with the proper filter and cover plates to protect your eyes from sparks and the rays of the arc when welding or observing open arc welding. Headshield and filter lens should conform to ANSI Z87.1 standards.
- 4.b. Use suitable clothing made from durable flame-resistant material to protect your skin and that of your helpers from the arc rays.
- 4.c. Protect other nearby personnel with suitable, non-flammable screening and/or warn them not to watch the arc nor expose themselves to the arc rays or to hot spatter or metal.



FUMES AND GASES can be dangerous.

- 5.a. Welding may produce fumes and gases hazardous to health. Avoid breathing these fumes and gases. When welding, keep your head out of the fume. Use enough ventilation and/or exhaust at the arc to keep fumes and gases away from the breathing zone. **When welding with electrodes which require special ventilation such as stainless or hard facing (see instructions on container or MSDS) or on lead or cadmium plated steel and other metals or coatings which produce highly toxic fumes, keep exposure as low as possible and below Threshold Limit Values (TLV) using local exhaust or mechanical ventilation. In confined spaces or in some circumstances, outdoors, a respirator may be required. Additional precautions are also required when welding on galvanized steel.**
- 5.b. Do not weld in locations near chlorinated hydrocarbon vapors coming from degreasing, cleaning or spraying operations. The heat and rays of the arc can react with solvent vapors to form phosgene, a highly toxic gas, and other irritating products.
- 5.c. Shielding gases used for arc welding can displace air and cause injury or death. Always use enough ventilation, especially in confined areas, to insure breathing air is safe.
- 5.d. Read and understand the manufacturer's instructions for this equipment and the consumables to be used, including the material safety data sheet (MSDS) and follow your employer's safety practices. MSDS forms are available from your welding distributor or from the manufacturer.
- 5.e. Also see item 1.b.

Mar '95

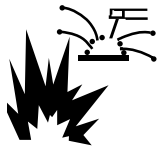

WELDING SPARKS can cause fire or explosion.

6.a. Remove fire hazards from the welding area. If this is not possible, cover them to prevent the welding sparks from starting a fire.

Remember that welding sparks and hot materials from welding can easily go through small cracks and openings to adjacent areas. Avoid welding near hydraulic lines. Have a fire extinguisher readily available.

- 6.b. Where compressed gases are to be used at the job site, special precautions should be used to prevent hazardous situations. Refer to "Safety in Welding and Cutting" (ANSI Standard Z49.1) and the operating information for the equipment being used.
- 6.c. When not welding, make certain no part of the electrode circuit is touching the work or ground. Accidental contact can cause overheating and create a fire hazard.
- 6.d. Do not heat, cut or weld tanks, drums or containers until the proper steps have been taken to insure that such procedures will not cause flammable or toxic vapors from substances inside. They can cause an explosion even though they have been "cleaned". For information, purchase "Recommended Safe Practices for the Preparation for Welding and Cutting of Containers and Piping That Have Held Hazardous Substances", AWS F4.1 from the American Welding Society (see address above).
- 6.e. Vent hollow castings or containers before heating, cutting or welding. They may explode.
- 6.f. Sparks and spatter are thrown from the welding arc. Wear oil free protective garments such as leather gloves, heavy shirt, cuffless trousers, high shoes and a cap over your hair. Wear ear plugs when welding out of position or in confined places. Always wear safety glasses with side shields when in a welding area.
- 6.g. Connect the work cable to the work as close to the welding area as practical. Work cables connected to the building framework or other locations away from the welding area increase the possibility of the welding current passing through lifting chains, crane cables or other alternate circuits. This can create fire hazards or overheat lifting chains or cables until they fail.
- 6.h. Also see item 1.c.

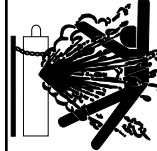

CYLINDER may explode if damaged.

7.a. Use only compressed gas cylinders containing the correct shielding gas for the process used and properly operating regulators designed for the gas and pressure used. All hoses, fittings, etc. should be suitable for the application and maintained in good condition.

- 7.b. Always keep cylinders in an upright position securely chained to an undercarriage or fixed support.
- 7.c. Cylinders should be located:
 - Away from areas where they may be struck or subjected to physical damage.
 - A safe distance from arc welding or cutting operations and any other source of heat, sparks, or flame.
- 7.d. Never allow the electrode, electrode holder or any other electrically "hot" parts to touch a cylinder.
- 7.e. Keep your head and face away from the cylinder valve outlet when opening the cylinder valve.
- 7.f. Valve protection caps should always be in place and hand tight except when the cylinder is in use or connected for use.
- 7.g. Read and follow the instructions on compressed gas cylinders, associated equipment, and CGA publication P-1, "Precautions for Safe Handling of Compressed Gases in Cylinders," available from the Compressed Gas Association 1235 Jefferson Davis Highway, Arlington, VA 22202.



FOR ELECTRICALLY powered equipment.

- 8.a. Turn off input power using the disconnect switch at the fuse box before working on the equipment.
- 8.b. Install equipment in accordance with the U.S. National Electrical Code, all local codes and the manufacturer's recommendations.
- 8.c. Ground the equipment in accordance with the U.S. National Electrical Code and the manufacturer's recommendations.

Mar '95

PRÉCAUTIONS DE SÛRETÉ

Pour votre propre protection lire et observer toutes les instructions et les précautions de sûreté spécifiques qui paraissent dans ce manuel aussi bien que les précautions de sûreté générales suivantes:

Sûreté Pour Soudage A L'Arc

1. Protégez-vous contre la secousse électrique:
 - a. Les circuits à l'électrode et à la pièce sont sous tension quand la machine à souder est en marche. Eviter toujours tout contact entre les parties sous tension et la peau nue ou les vêtements mouillés. Porter des gants secs et sans trous pour isoler les mains.
 - b. Faire très attention de bien s'isoler de la masse quand on soude dans des endroits humides, ou sur un plancher métallique ou des grilles métalliques, principalement dans les positions assis ou couché pour lesquelles une grande partie du corps peut être en contact avec la masse.
 - c. Maintenir le porte-électrode, la pince de masse, le câble de soudage et la machine à souder en bon et sûr état de fonctionnement.
 - d. Ne jamais plonger le porte-électrode dans l'eau pour le refroidir.
 - e. Ne jamais toucher simultanément les parties sous tension des porte-électrodes connectés à deux machines à souder parce que la tension entre les deux pinces peut être le total de la tension à vide des deux machines.
 - f. Si on utilise la machine à souder comme une source de courant pour soudage semi-automatique, ces précautions pour le porte-électrode s'appliquent aussi au pistolet de soudage.
2. Dans le cas de travail au dessus du niveau du sol, se protéger contre les chutes dans le cas où on reçoit un choc. Ne jamais enrouler le câble-électrode autour de n'importe quelle partie du corps.
3. Un coup d'arc peut être plus sévère qu'un coup de soleil, donc:
 - a. Utiliser un bon masque avec un verre filtrant approprié ainsi qu'un verre blanc afin de se protéger les yeux du rayonnement de l'arc et des projections quand on soude ou quand on regarde l'arc.
 - b. Porter des vêtements convenables afin de protéger la peau de soudeur et des aides contre le rayonnement de l'arc.
 - c. Protéger l'autre personnel travaillant à proximité au soudage à l'aide d'écrans appropriés et non-inflammables.
4. Des gouttes de laitier en fusion sont émises de l'arc de soudage. Se protéger avec des vêtements de protection libres de l'huile, tels que les gants en cuir, chemise épaisse, pantalons sans revers, et chaussures montantes.
5. Toujours porter des lunettes de sécurité dans la zone de soudage. Utiliser des lunettes avec écrans latéraux dans les zones où l'on pique le laitier.
6. Eloigner les matériaux inflammables ou les recouvrir afin de prévenir tout risque d'incendie dû aux étincelles.
7. Quand on ne soude pas, poser la pince à un endroit isolé de la masse. Un court-circuit accidentel peut provoquer un échauffement et un risque d'incendie.
8. S'assurer que la masse est connectée le plus près possible de la zone de travail qu'il est pratique de le faire. Si on place la masse sur la charpente de la construction ou d'autres endroits éloignés de la zone de travail, on augmente le risque de voir passer le courant de soudage par les chaînes de levage, câbles de grue, ou autres circuits. Cela peut provoquer des risques d'incendie ou d'échauffement des chaînes et des câbles jusqu'à ce qu'ils se rompent.
9. Assurer une ventilation suffisante dans la zone de soudage. Ceci est particulièrement important pour le soudage de tôles galvanisées plombées, ou cadmiées ou tout autre métal qui produit des fumées toxiques.
10. Ne pas souder en présence de vapeurs de chlore provenant d'opérations de dégraissage, nettoyage ou pistologie. La chaleur ou les rayons de l'arc peuvent réagir avec les vapeurs du solvant pour produire du phosgène (gas fortement toxique) ou autres produits irritants.
11. Pour obtenir de plus amples renseignements sur la sûreté, voir le code "Code for safety in welding and cutting" CSA Standard W 117.2-1974.

PRÉCAUTIONS DE SÛRETÉ POUR LES MACHINES À SOUDER À TRANSFORMATEUR ET À REDRESSEUR

1. Relier à la terre le châssis du poste conformément au code de l'électricité et aux recommandations du fabricant. Le dispositif de montage ou la pièce à souder doit être branché à une bonne mise à la terre.
2. Autant que possible, l'installation et l'entretien du poste seront effectués par un électricien qualifié.
3. Avant de faire des travaux à l'intérieur de poste, la débrancher à l'interrupteur à la boîte de fusibles.
4. Garder tous les couvercles et dispositifs de sûreté à leur place.

Thank You

for selecting a **QUALITY** product by Lincoln Electric. We want you to take pride in operating this Lincoln Electric Company product
••• as much pride as we have in bringing this product to you!

Please Examine Carton and Equipment For Damage Immediately

When this equipment is shipped, title passes to the purchaser upon receipt by the carrier. Consequently, Claims for material damaged in shipment must be made by the purchaser against the transportation company at the time the shipment is received.

Please record your equipment identification information below for future reference. This information can be found on your machine nameplate.

Model Name & Number _____

Code & Serial Number _____

Date of Purchase _____

Whenever you request replacement parts for or information on this equipment always supply the information you have recorded above.

Read this Operators Manual completely before attempting to use this equipment. Save this manual and keep it handy for quick reference. Pay particular attention to the safety instructions we have provided for your protection. The level of seriousness to be applied to each is explained below:

⚠ WARNING

This statement appears where the information **must** be followed **exactly** to avoid **serious personal injury** or **loss of life**.

⚠ CAUTION

This statement appears where the information **must** be followed to avoid **minor personal injury** or **damage to this equipment**.

EXPLANATION OF SYMBOLS THAT APPEAR ON THIS EQUIPMENT

O

OFF

I

ON

TABLE OF CONTENTS

Page

Installation	Section A
Technical Specifications	A-1
Product Description	A-2
Warranty	A-2
Safety Precautions.....	A-3
Product Overview	A-3
Filling the Reservoir	A-4
Water Line Connection	A-4
Horizontally Mounting Magnum Coolers to Lincoln TIG Power Sources	A-5
Vertically Mounting Magnum Coolers to Lincoln Undercarriages	A-5
Water Cooled Equipment Installation	A-8
K440-1 LN-7 GMA Wire Feeder with Gas and Water Solenoid Valve	A-10
K527 Water Solenoid Kit for LN-7.....	A-10
K529-10 Power Input Cable with Water and Gas Lines	A-11
Operation	Section B
Safety Precautions	B-1
Operating Precautions	B-1
Lighted Power Switch	B-1
Turning the System On.....	B-1
Magnum System Monitor.....	B-2
Demand System with Water Valve or Solenoid	B-2
Surge Protection	B-2
Fan Motor and Fan Blade	B-2
Pump and Pump Pressure.....	B-2
Pump Failure	B-3
Cooling Efficiency	B-3
Accessories	Section C
Accessories	C-1
Maintenance	Section D
Safety Precautions	D-1
Heat Exchanger Maintenance	D-1
Reservoir Maintenance.....	D-1
Troubleshooting	Section E
Safety Precautions.....	E-1
How to Use Troubleshooting Guide.....	E-1
Troubleshooting Guide	E-2
Wiring Diagrams	Section F
Wiring Diagrams	F-1,F-2
Parts List	Appendix

TECHNICAL SPECIFICATIONS – MAGNUM COOLERS 10-I AND 20-I

		Model	
		Cooler 10-I	Cooler 20-I
Product No.		K873-1	K879-1
Input		220V 50/60 Hz 1 Phase	220V 50/60 Hz 1 Phase
Current Draw at Input		.75 Amps	1.25 Amps
Rated Current Draw		1.0 Amps	1.6 Amps
Operating Pressure		45 psi (310 kPa) (3.0 bar)	60 psi (410 kPa) (4.0 bar)
Shutdown Pressure (No delay after flow is stopped)		60-65 psi (414-446 kPa) (4.0-4.4 bar)	
Flow Range		0.1 to 0.8 gal/min (0.4 to 3.0 liters/min)	
Typical Operating Flow	MIG	with Magnum 15' (4.5m) gun 0.55-0.60 gal/min (2.1-2.3 liters/min)	
	TIG	with Magnum 12.5' (3.8m) torch 0.25-0.30 gal/min (1.0-1.2 liters/min)	
	Open Flow	0.8 (3.0 liters/min)	
Reservoir Size		2.0 ga. (8.0 liters)	
Coolant Requirement		<p>For Use Above Freezing: Tap, distilled, de-ionized, mineral water or well water.</p> <p>For Use Below Freezing: 50% water and 50% automotive antifreeze mixture such as Prestone, Peak or Zerex or 50% water and 50% pure ethylene glycol mixture or any water alcohol mixture.</p> <p>DO NOT USE: Prepackaged welding industry coolants. These coolants may contain oil-based substances which attack the plastic components in the pump of the Magnum Cooler and severely reduce pump life.</p>	
Weight		Shipping 30 lbs. (13.6 kg)	34 lbs. (15.4 kg)
	Reservoir Full	43 lbs. (19.5 kg)	47 lbs. (21.3 kg)
Dimensions	L	9.0 in. (229mm)	9.0 in. (229mm)
	W	9.0 in. (229mm)	9.0 in. (229mm)
	H Top Face	26.5 in. (673mm)	32.00 in. (815mm)
	H Top Handle	28.75 in. (730mm)	34.25 in. (870mm)
Undercarriage Use		K874	K840-1*, K841-1*, K842-1*, K874

* Not available at the time of printing.

PRODUCT DESCRIPTION

Magnum Coolers 10-I and 20-I are stand alone recirculating cooling systems designed for use with water cooled TIG, MIG, PAC (Plasma Arc Cutting) and PAW (Plasma Arc Welding) guns and torches. Additional applications include resistance welding, induction heating and water cooled fixtures such as EDM's and small Verti-Shield dams. The connection block located at the back of the Cooler contains 5/8-18 left hand female thread. A 5/8-18 left hand nut and matching nipple are supplied with each Magnum Cooler 10-I and Cooler 20-I unit to convert hoses that may have different connectors. The international Cooler 10-I and 20-I are also furnished with a bracket so that the Cooler can be anchored at the back of a Lincoln K874 double cylinder undercarriage.

With lower 45 psi (310 kPa) (3.0 bar) output pressure delivery to increase TIG torch component life, Magnum Cooler 10-I is made for all water cooled TIG applications and low to medium duty MIG applications. The higher 60 psi (410 kPa) (4.0 bar) output pressure delivery of Magnum Cooler 20-I supports higher demand water cooled applications without decreasing component life.

The Magnum Coolers bring new technology in the areas of pump, heat exchanger and reservoir designs to the water cooler market. These technologies allow the Magnum Coolers to be lighter in weight, lower in energy consumption, mounted either vertically or horizontally, and operated even in the case of a "soft" pump failure. The unique "soft" pump failure feature allows some pump stages to continue to pump coolant even if one or two stages have failed.

The unique "On-Demand" system (when used with a water valve or solenoid in the system) only pumps coolant when it is needed, saves energy, reduces noise and increases pump and fan motor life by turning off the system between welds.

The Magnum Cooler is capable of operating continuously; however, the "on-demand" feature is strongly recommended in **ALL APPLICATIONS** TO ASSURE GOOD PUMP AND MOTOR LIFE.

Magnum Cooler are easy to service. Removal of the front case provides access to all internal components. The Phillips head fasteners used to anchor the casing of the unit match those of the pump and other internal component connections. In this manner, an operator can repair all major components using just a Phillips head screwdriver.

WARRANTY

Warranty for this product is one year after the date of purchase. For any warranty claim, contact a certified Lincoln service center.

INSTALLATION

⚠ WARNING

ELECTRIC SHOCK can kill.

- Disconnect input power by removing plug from receptacle before working inside Cooler.
- Use only grounded receptacle.
- Do not remove the power cord ground prong.
- Do not touch electrically “hot” parts inside Cooler.
- Have qualified personnel do the installation, maintenance and troubleshooting work.

The FILL CAP is at the front of the unit (C).

Cap removal: While pressing the bulls-eye inward, grip the tab and remove the cap with a peeling motion.

Cap replacement: Install by pressing inward on the bulls-eye; the cap will “snap” into position.

The coolant FLOW INDICATOR is accessed by removal of the fill cap. Actual return flow is directly visible, via the fill opening (D) with the unit in vertical or horizontal position.

PRODUCT OVERVIEW

The LIGHTED POWER SWITCH is located at the left side of the control panel (A). Cooler will be “ON” when pressed to “|”.

Coolant INLET and OUTLET fittings are found at the rear of the unit (B). They are welding industry standard English left-hand fittings for water coolant lines. The right side fitting is marked “coolant out” (coolant supply to the welding equipment); the left side fitting is marked “coolant in” (coolant returning from the welding equipment).

Air flow vents (E).

FIGURE 1

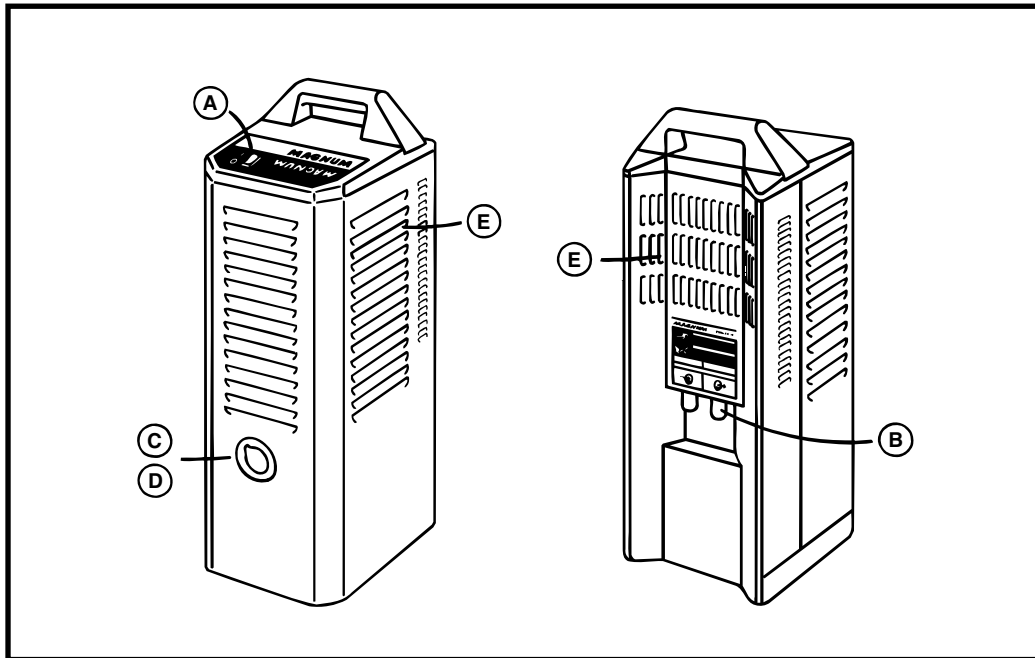

MAGNUM COOLER 10-I & 20-I



The case front sheet metal design allows for ease of access to repair all internal components. The Phillips head fasteners used to secure the casing match the style of fasteners used in the pump head and other major components. In this manner, an operator can repair all major components in the unit using just a Phillips head screwdriver. The case back trapezoidal shape eliminates the possibility of the exit airflow of the Cooler being choked when the Cooler is operated lying horizontally. The exiting airflow is also pushed back away from the unit so that hot air does not recirculate through the louvers in the case front.

A blow molded, high density one piece polyethylene housing serves as both the reservoir and support frame for the Coolers. The use of polyethylene plastic gives a design that is lightweight and durable.

FILLING THE RESERVOIR

PROPER COOLANT ADDITION

FOR USE ABOVE FREEZING: Tap, distilled, deionized, mineral water, or well water.

FOR USE BELOW FREEZING: 50% water and 50% automotive antifreeze mixture such as Prestone, Peak or Zerex or 50% water and 50% pure ethylene glycol mixture or any water alcohol mixture.

DO NOT USE: Prepackaged welding industry coolants. These coolants may contain oil-based substances which attack the plastic components in the pump of the Magnum Cooler and severely reduce pump life. Once added to the Cooler, the substances are virtually impossible to purge from the water lines and heat exchanger.

To avoid freeze damage and water leakage in shipment, every Cooler 10-I and 20-I unit is delivered empty with no coolant in the system. To fill the unit, locate the plastic snap-on reservoir fill cap at the front middle of the unit. Remove the fill cap by pressing the center of the cap inward while pulling at the tab on the outer edge.

NOTE: The unit can be filled either vertically or horizontally. **UNPLUG THE COOLER BEFORE FILLING THE RESERVOIR.**

For best results when using the Magnum Cooler with Lincoln guns or torches, use distilled, deionized or demineralized water, although if not available, tap water can be used. If protection from freezing is desired, use a 1 gallon (4 liter) automotive antifreeze and 1 gallon (4 liter) tap water mixture. An alcohol or glycol mixture with water is also acceptable.

When using the Magnum Cooler with other products, consult the manufacturer's recommendations for coolant. **Do not use oil based coolants.**

The unit can be filled either vertically or horizontally. **UNPLUG THE COOLER BEFORE FILLING THE RESERVOIR.**

Upright: Tilt the unit backward and pour 2 gallons (8.0 liters) of coolant into the reservoir fill hole through a funnel.

or

If 1 gallon (4 liters) antifreeze or fill bottle is available, tilt the unit forward until the bottle mates with the reservoir fill hole. Then tilt the unit backward until the fill bottle is emptied. Fill the unit with 2 gallons (8 liters) of coolant.

Lying down: Carefully add 2 gallons (8.0 liters) of coolant through a funnel into the reservoir fill hole. **AVOID SPILLING COOLANT INTO THE FRONT CASING OF THE UNIT.**

Unit will be full when coolant lies just below the reservoir opening with the unit in its upright position.

NOTE: DO NOT ADD MORE THAN 2 GALLONS (8 LITERS) OF COOLANT INTO THE RESERVOIR. The fill cap contains a pressure release air hole which must not be blocked by overfilling the reservoir with coolant.

Be certain to replace the reservoir fill cap when the reservoir is full. Simply press on the inside center of the fill cap until the cap snaps into place. Operation of the Magnum Cooler without the fill cap in place can cause poor cooling efficiency, evaporation loss of coolant, and low product life.

WATER LINE CONNECTION

Two connector nuts and mating nipples are supplied in each Cooler 10-I and 20-I model. The connector and nipple fit tightly onto 4.0mm (5/32") to 4.0mm (3/16") inner diameter hose, but if clamped tightly to the hose can fit up to 6.4mm (.250") inner diameter hose.

To install water lines onto the Cooler, check if your coolant hose mates with the 5/8-18 left hand female thread in the connector block at the back of the unit.

If the connector nut on your water hose does not mate with the connector block at the back of the Magnum Cooler:

Remove the connector nut from the INLET hose by making a straight cut 6-12mm (1/4-1/2") away from the end of the nipple located inside of the hose. Take the nipple and the connector nut supplied with the

Cooler and insert the nipple into the connector nut so that the threaded end of the connector nut points away from the barbed end of the nipple. Twist the barbed end of the nipple into the hose until the shoulder of the nipple is flush with the end of the hose. Secure the hose onto the nipple with a hose clamp to insure that the connection is water tight. No water can leak from the connection if it is properly attached. Repeat the procedure for the OUTLET hose. When complete, reference Figure 2 and follow the connection procedure detailed below for connector nuts that mate to the Magnum Cooler connector block.

For additional water lines that do not mate with Magnum Cooler connections, order:

Order: (2) T15007-2 Connector Nuts*
(2) T15008 Nipples*
(2) S10888-35 Hose Clamps*

For all Lincoln products and those with a connector nut on the water hose which mates with the connector block at the back of a Magnum Cooler:

Save the two connector nuts and nipples provided with the unit for future use. (Reference Figure 2). Take the water INLET hose (colored or tagged blue on most hoses) and thread it into the coolant OUT line located on the right hand side of the connector block at the back of the Cooler. Secure the connector nut of the hose tightly into the connector block with a wrench so that leaking does not occur. Then take the OUTLET hose (colored or tagged red on most hoses) and thread it into the coolant IN line located on the left hand side of the connector block. Again, tightly secure the connector nut of the hose into the connector block of the Cooler with a wrench to insure that no leaking occurs. BE CERTAIN THAT NO LEAKS EXIST WHEN COOLER IS TURNED ON. A LEAK WILL DEplete RESERVOIR VOLUME, CAUSE POOR OR COOLING PERFORMANCE AND REDUCE GUN OR TORCH LIFE.

NOTE: Be certain that only 5/8-18 left hand male nuts with clean and smooth threads are used on your water hoses. Poor connections cause water to leak at connector block, down hose lines, and eventually out the case sides of the unit.

* The connector and nipples listed fit tightly onto 4mm (5/32") to 4.8mm (3/16") inner diameter hose, but if clamped tightly to the hose, can fit up to 6.4mm (1/4" inner diameter hose).

HORIZONTALLY MOUNTING MAGNUM COOLERS ON LINCOLN TIG POWER SOURCES

Magnum Coolers can be mounted either upright or horizontally. For a complete compact system, Magnum 10-I or 20-I Cooler can be mounted horizontally on the roof of Lincoln TIG Power Sources using the optional K559-2 Horizontal TIG Mounting Bracket. For proper installation, follow the instructions provided with the kit. (See Figures 3a and 3b)

VERTICALLY MOUNTING MAGNUM COOLERS TO LINCOLN UNDERCARRIAGES K874, K840-1*, K841-1*, or K842-1*

When placing the Cooler 10-I or 20-I at the back of a Lincoln Undercarriage used in tandem with a Lincoln MIG power source, order K559-3 Magnum Cooler MIG Mounting Bracket.

Reference Figure 3c and Table 2 for proper connection of the bracket to the back bolt pattern of the Cooler. With the four Phillips head screws supplied, align the bracket onto the back of the Cooler at the proper holes displayed in Figure 3c. Do not fully tighten the bracket allowing the bracket to slightly move up and down. Place the Cooler at the back right of the undercarriage so that the lip of the Cooler bracket rests on the top of the undercarriage upper cylinder support. Align the holes of the Cooler bracket with the holes on the undercarriage upper cylinder support. Fasten the Cooler bracket with the holes on the undercarriage upper cylinder support. Fasten the Cooler bracket onto the undercarriage support with both 1/4-20 bolts, 1/4-20 hex nuts, plain washers and lock washers provided. Be certain to tighten all the fasteners when the installation is complete.

* Not available at time of printing.

FIGURE 2

Inlet and Outlet Hose Connection Diagram

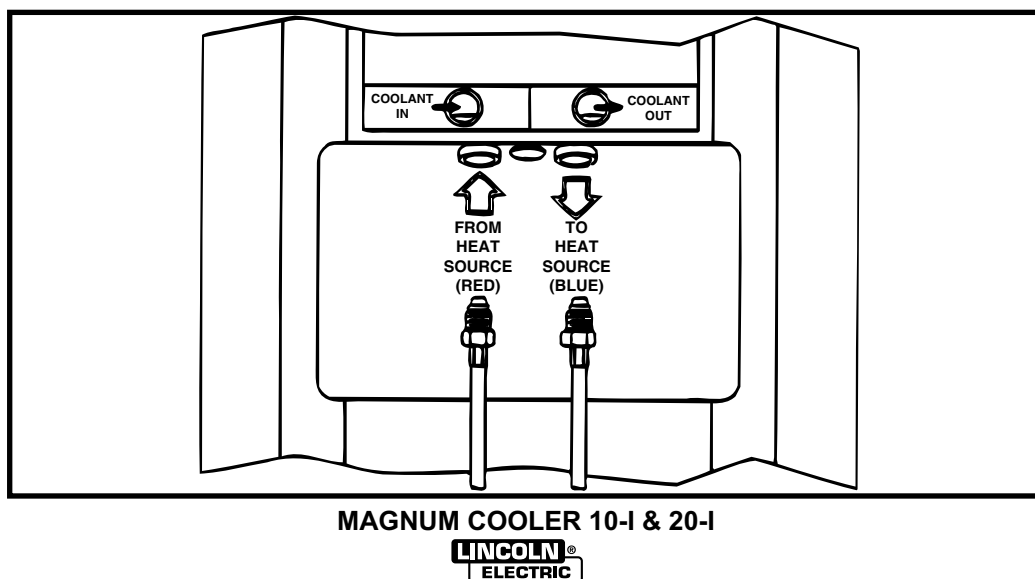
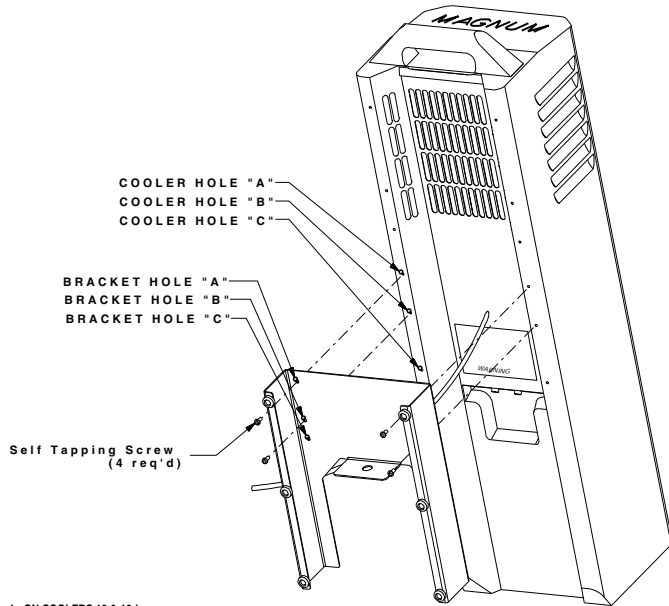

FIGURE 3a

FIGURE 3b



1. ON COOLERS 10 & 10-I:
Align holes A & C of mounting bracket with holes B & C of Magnum Cooler. Secure bracket to the back of Cooler with 4 self tapping screws provided.
- ON COOLERS 20 & 20-I:
Align holes A & B of mounting bracket with holes A & B of Magnum Cooler. Secure bracket to the back of Cooler with 4 self tapping screws provided.
2. Route all water line connections onto connection block at back of Cooler as outlined in the IM manual provided with the Magnum Cooler.

NOTE: FOR PROPER INSTALLATION WHEN USED WITH LINCOLN K835, K840, K841 OR K842 UNDERCARRIAGES, THE RUBBER FEET MAY NEED TO BE REMOVED FROM THE BOTTOM OF THE MOUNTING BRACKET.

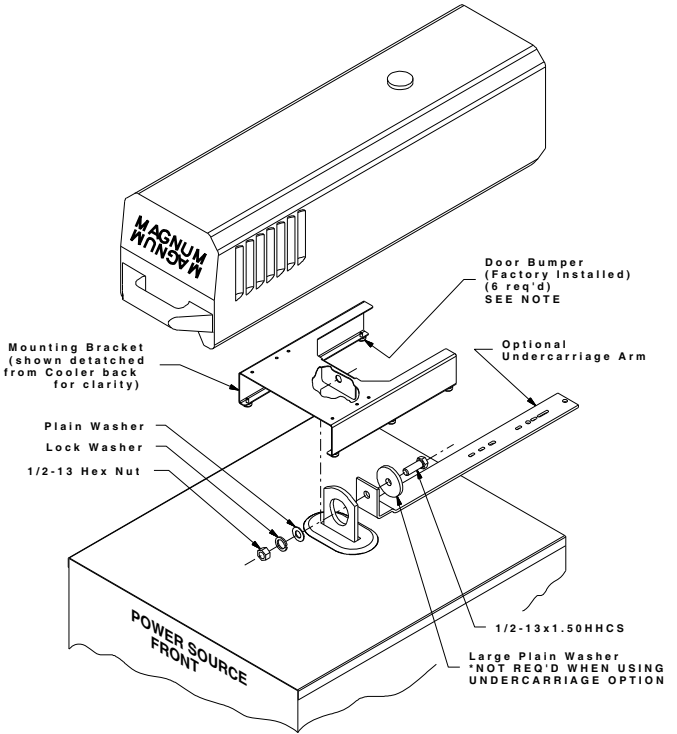

TABLE 2

Recommended Magnum Cooler Use with Lincoln Power Source / Undercarriage Combination

Power Source	Cooler	Undercarriage	Figure 3c Mtg. Bkt. Scheme
CV-200-I	Cooler 10-I	K874	A
CV-300-I	Cooler 10-I or 20-I**	K874	A or C
CV-400-I	Cooler 10-I or 20-I**	K874	B or D
CV-500-I	Cooler 20-I	K841-1*	E
R3R-375-I	Cooler 20-I	K841-1*	E
R3R-500-I	Cooler 20-I	K841-1*	E
R3R-600-I	Cooler 20-I	K841-1*	E

** Use 20-I model for demanding welding applications.

* Not available at the time of printing.

FIGURE 3c

Undercarriage Mounting Bracket Layout

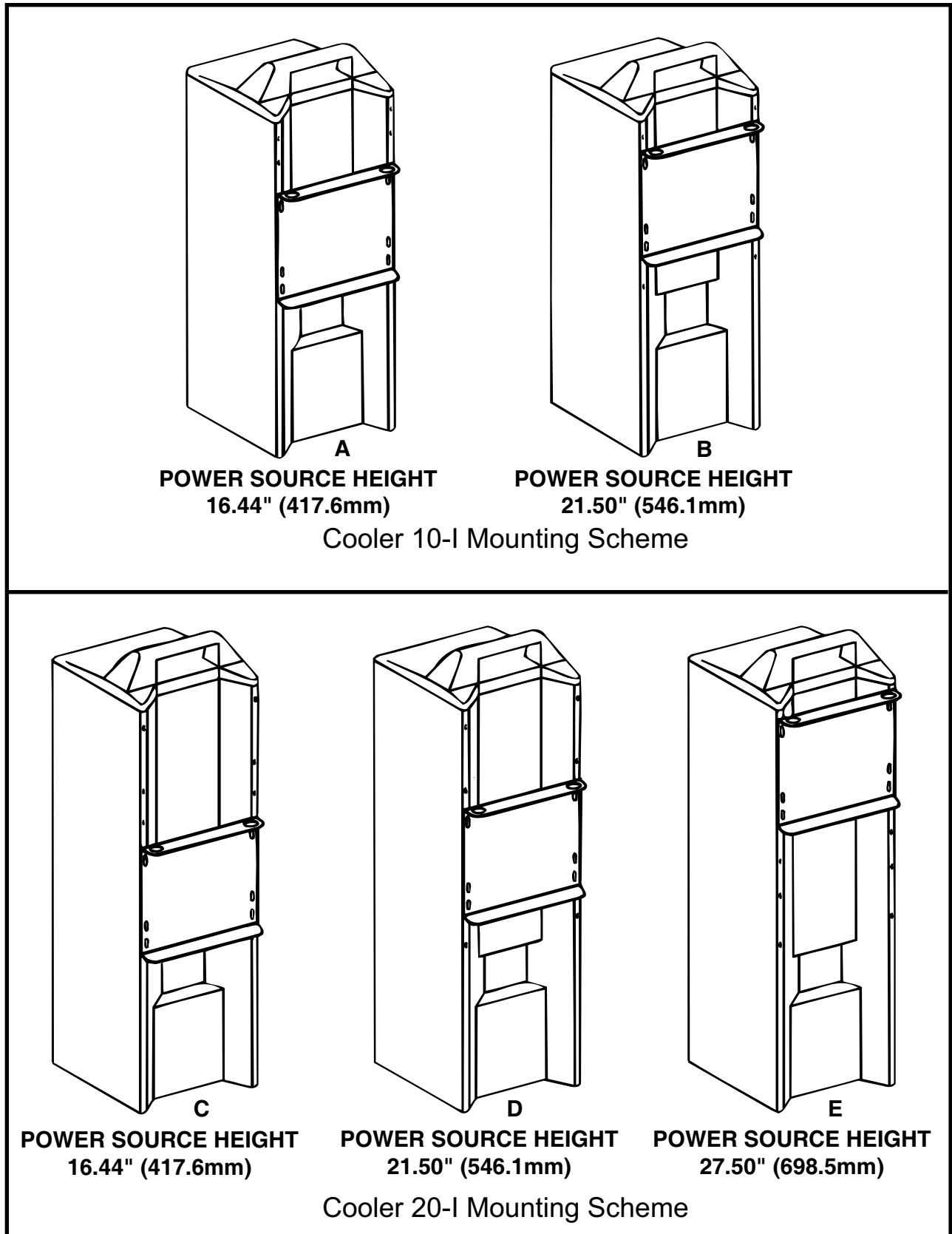

WATER COOLED EQUIPMENT INSTALLATION

NOTE: Magnum Coolers operate at 45 psi (3.0 bar) (310 kPa) of pressure for Cooler 10-I and 60 psi (4.0 bar) (414 kPa) of pressure for Cooler 20-I. When used in the demand system, the pressure in the supply hose to the water solenoid or valve can surge to 20 psi (1.4 bar) (138 kPa) above holding pressure just before shutdown. The holding pressure will be 60-65 psi (4.0-4.4 bar) (414-448 kPa). When using the Magnum Cooler with other water cooled TIG, MIG and plasma systems, consult the manufacturer's instruction manual.

FIGURE 4

Water Cooled TIG Torch Connection

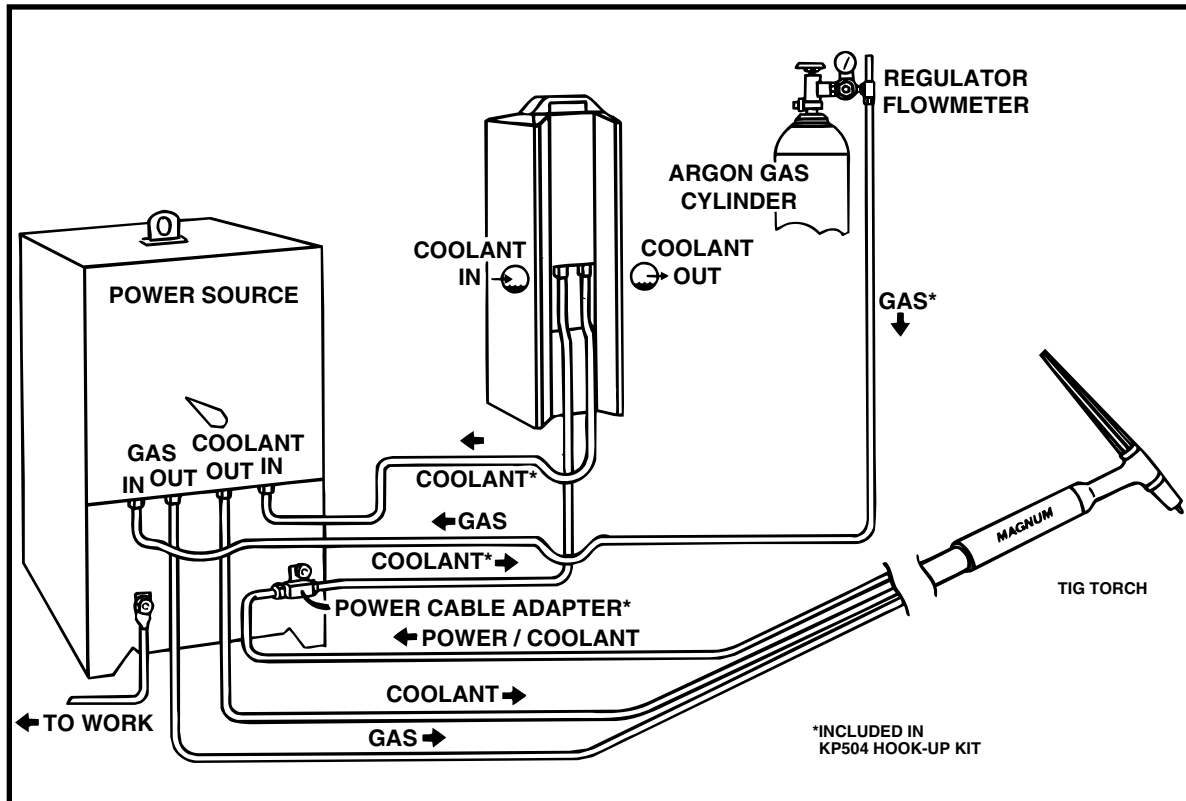

MAGNUM COOLER 10-I & 20-I

FIGURE 5

Water Cooled MIG Gun Connection

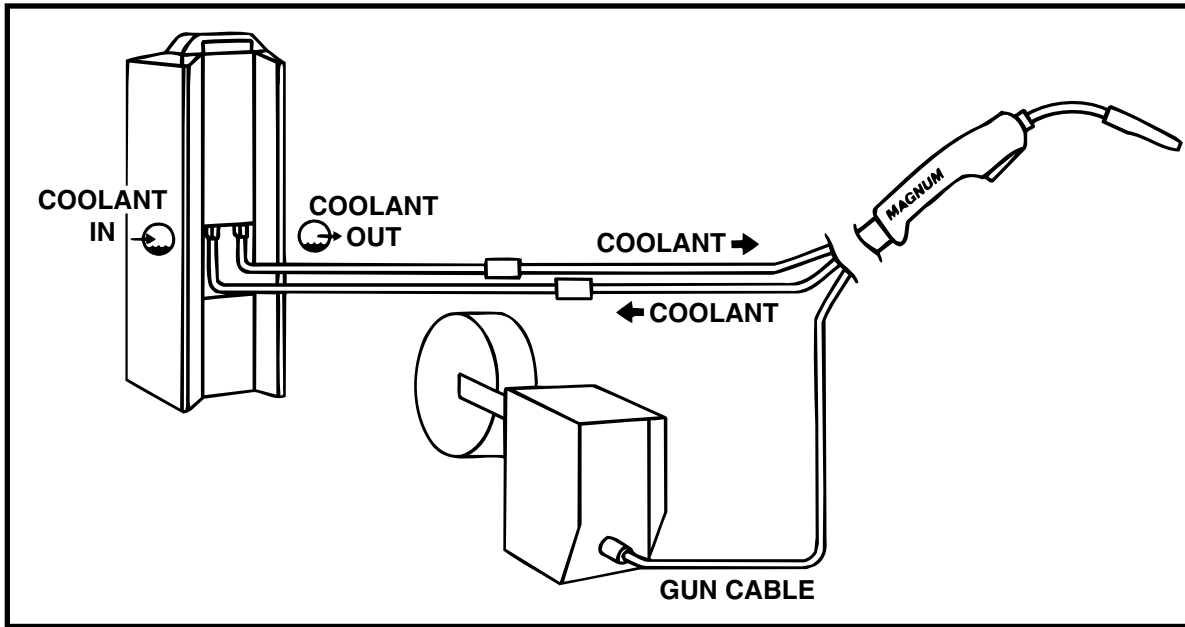
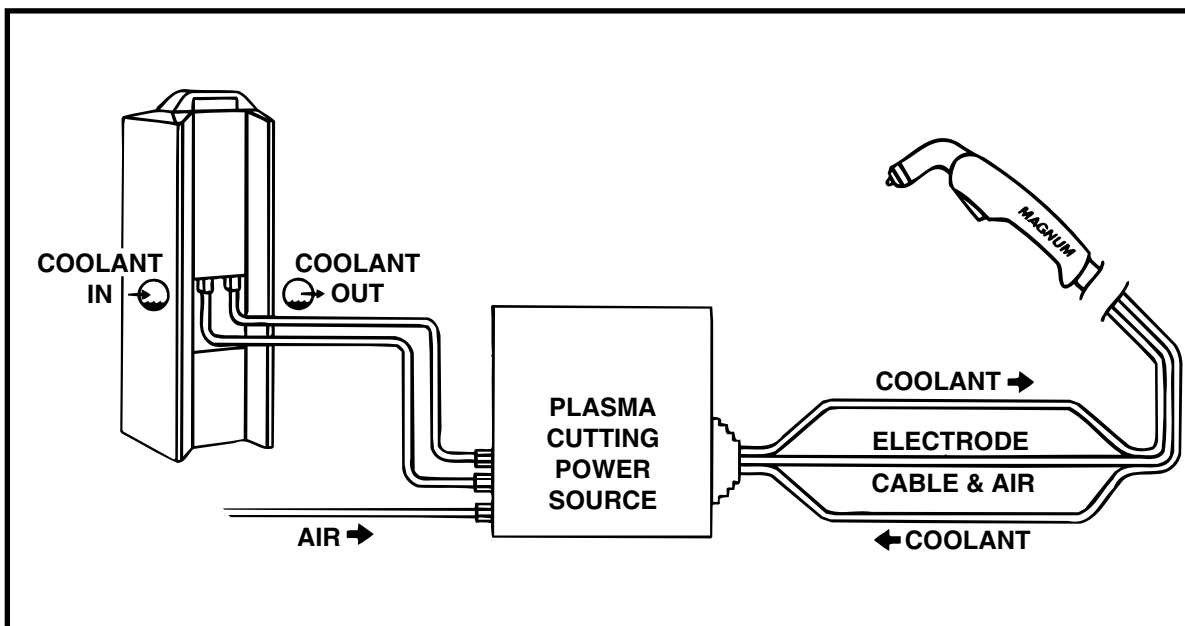

FIGURE 6

Water Cooled Plasma System Connection



MAGNUM COOLER 10-I & 20-I



K440-1 LN-7 GMA WIRE FEEDER WITH GAS AND WATER SOLENOID VALVE

The K440-1 LN-7 GMA wire feeder is equipped with internal water lines and external connectors for attachment to a water cooled MIG gun and a Magnum Cooler. The water solenoid control of the K440-1 LN-7 GMA enables the feeder to trigger the demand system of a Magnum Cooler. (Reference Operation Section for an explanation of the Magnum Cooler demand system). Follow the instruction manual supplied with the wire feeder and Figure 7 for proper connection of the K440-1 LN-7 GMA wire feeder to a Magnum Cooler and a water cooled MIG gun.

K527 WATER SOLENOID KIT FOR LN-7 2-ROLL AND LN-7 2-ROLL AND 4-ROLL GMA WIRE FEEDERS

For LN-7 2-Roll Model Above Code 9484
For LN-7 GMA 2-Roll and 4-Roll Models Above Code 9100

The K527 water solenoid kit can be added to an LN-7 or LN-7 GMA wire feeder for conversion from an air cooled to a water cooled MIG system. The added solenoid control enables the feeder to trigger the demand system of a Magnum Cooler. Follow the kit instructions provided for proper installation of the K527 water solenoid kit to an LN-7 or LN-7 GMA wire feeder and Figure 7 for proper connection of the converted wire feeder to a Magnum Cooler and a water cooled MIG gun. Reference Operation Section for an explanation of the Magnum Cooler demand system.

FIGURE 7

Connection to Wire Feeder Equipped with Solenoid Control

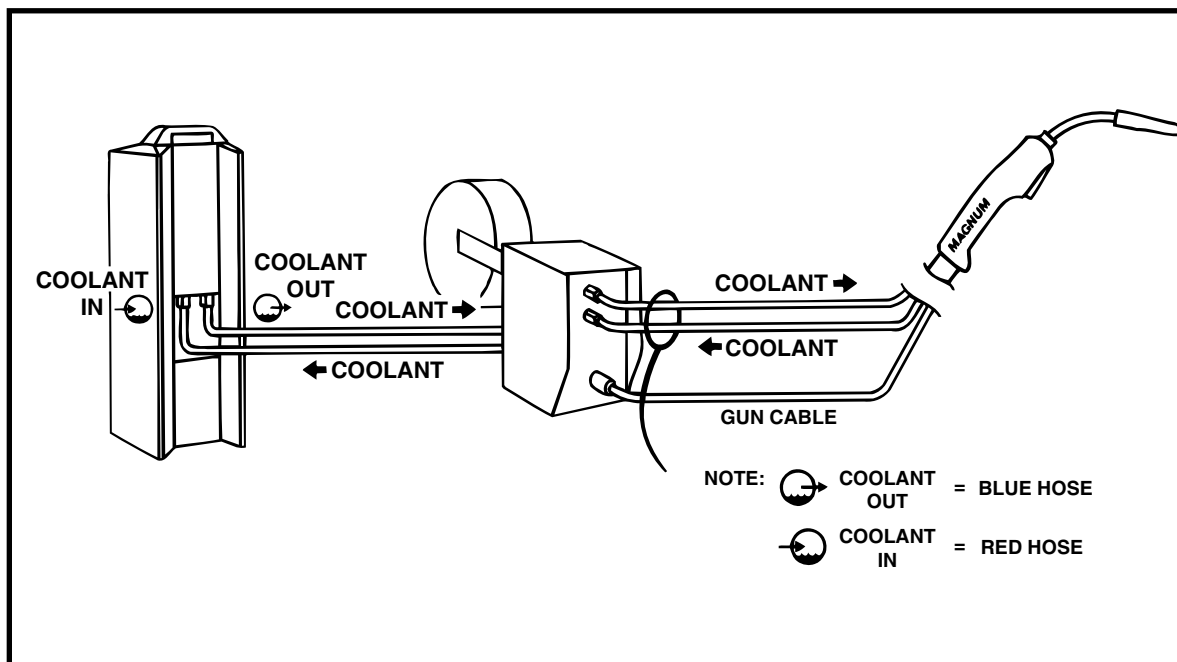

K529-10 POWER INPUT CABLE WITH WATER AND GAS LINES

The K529 power input cable connects from the front of a Lincoln power source to the back of LN-7 and LN-7 GMA wire feeders equipped with a water solenoid control. K529-10 is 10 ft. (3.0m) long and includes two water hoses and a gas line. The lengths of the two water hoses and gas line are designed for proper connection to a Magnum Cooler and a gas cylinder located on the back of a Lincoln K874, K840-1*, K841-1* or K842-1* double cylinder undercarriage. The water connections are 5/8-18 left hand thread while the gas connection is 5/8-18 right hand thread. Reference Figure 8 when using the K529 power input cable.

* Not available at time of printing.

Figure 8

K529-10 POWER INPUT CABLE CONNECTION

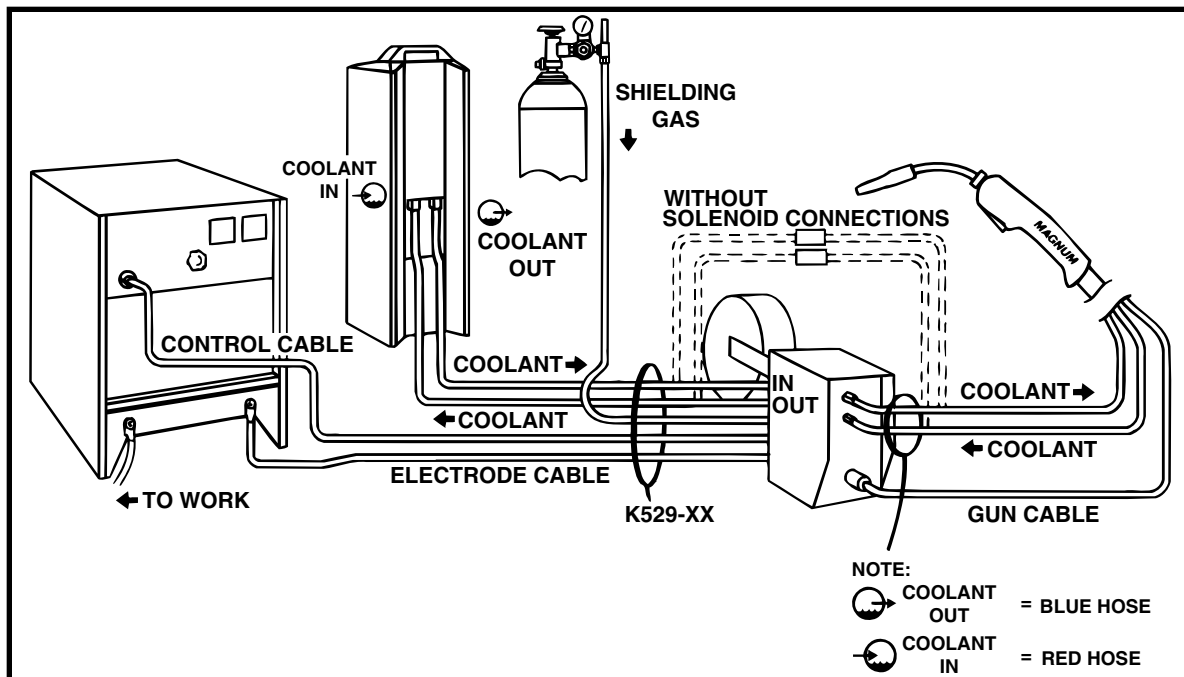

SAFETY PRECAUTIONS

⚠ WARNING

ELECTRIC SHOCK can kill.

- Do not touch electrically live parts or electrode with skin or wet clothing.
- Insulate yourself from work and ground.
- Always wear dry insulating gloves.



FUMES AND GASES can be dangerous.

- Keep your head out of fumes.
- Use ventilation or exhaust to remove fumes from breathing zone.



WELDING SPARKS can cause fire or explosion.

- Keep flammable material away.
- Do not weld on closed containers.



ARC RAYS can burn eyes and skin.

- Wear eye, ear and body protection.

See additional warning information at front of this operator's manual.

The following should always be observed when operating any Magnum Cooler:

- Never operate the Cooler with case off.
- Immersion in water around electrical lines can cause electrical shock.
- Never place fingers into openings of Cooler. Moving parts can injure.
- Unplug the Cooler before filling the reservoir.
- Never operate the Cooler with the reservoir fill cap off.

OPERATING PRECAUTIONS

The following should always be observed when operating any Magnum Cooler:

- Check the Magnum system monitor to verify adequate flow for the application.
- Check the reservoir daily.
- Keep the reservoir full especially after changing any water lines.

- Even when using the Magnum Cooler in an “on-demand” application, the power to the Cooler should be turned off when welding is not taking place for a long period of time.
- Be certain that the Cooler is on (power switch in the “I” position) before beginning to weld, especially when using the Cooler in the demand system.
- Never operate the Cooler with the reservoir fill cap removed.
- Avoid placing the Cooler near areas of extreme heat.
- Avoid placing the Cooler near a flux hopper or an area where dust build-up is extreme.
- Avoid kinking or putting sharp bends in any water lines.
- Keep all water lines clean.

LIGHTED POWER SWITCH

A long life, lighted power switch is located at the left side on the control panel. When switched “ON”, the switch will be pressed toward the “I” symbol.

Because it will only light when the Cooler is pumping coolant, the switch serves as an indicator for the Magnum system monitor. For proper operation, the switch should beam steadily when coolant is pumping and remain unlit when flow is stopped. Reference the Magnum system monitor sections for an explanation.

TURNING THE SYSTEM ON

After filling the reservoir and connecting the coolant hoses to the Magnum Cooler per the Installation Sections, plug the unit into an electrical receptacle for start-up operation. Be certain that the power input into the unit matches the Cooler's rated input. Both Cooler 10-I and 20-I cordsets contain a 90 angled CEE 7/4, 7/7 Schuko compatible plug. The plug mates with an auxiliary receptacle located at the back of many international Lincoln power sources for power supply to a Magnum Cooler 10-I and 20-I when placed at the back of a Lincoln K874, K840-1*, K841-1*, and K842-1* undercarriage.

* Not available at time of printing.

You will be able to hear the fan running and feel air flow out of the back of the unit when the Cooler is operating. The Cooler will run continuously when operated without a water solenoid or valve. If a water solenoid or valve is used, the Cooler will run for a short period of time until the demand system is activated and the unit shuts off.

When first starting the unit, check all of the water lines to insure that no water leaks are present. Water leakage causes poor welding performance, poor cooling performance, low welding component life and potential electrical safety hazards.

MAGNUM SYSTEM MONITOR

Always check the Magnum System Monitor before beginning to weld. The power switch light located at the top of the unit functions as the system monitor. The light will beam steadily when coolant is flowing and remain unlit when flow is stopped. The light will flicker if there is inadequate flow through the system. Be sure to check the operation periodically and each time your welding setup is changed.

Coolers are factory set to deliver coolant for the most common welding setups.

IF COOLANT STILL FLOWS, BUT THE LIGHT FLICKERS:

1. The System Monitor light indicates if there is a restriction somewhere downstream from the Cooler. Be certain that water lines and welding apparatus are not crimped, partially blocked or obstructed.
2. Uncoil the water lines to remove any kinks from the lines.
3. Unhook the input and output lines from the Cooler. Blow out the welding apparatus lines and/or connection lines to remove any particulate. Reattach and check flow again.

NOTE: If the system uses a water valve, check to make sure that the valve is working properly.

DEMAND SYSTEM WITH WATER VALVE OR SOLENOID

When linked to a water solenoid or valve, the demand system works as follows:

When the weld is complete and the trigger circuit opened, the solenoid stops water flow into the torch or the gun. The pump senses the buildup of pressure

and the internal components of the Cooler turn off. When the arc is started and the trigger and the solenoid are enabled, the system pressure is relieved and the Cooler immediately begins to run. When a water valve or solenoid is not used, the pump does not sense any build up of pressure and the Cooler runs continuously.

⚠ CAUTION

NEVER BYPASS THE COOLER POWER SWITCH.

When using a water valve or solenoid, be certain to turn the Magnum Cooler off ("O" position) when not in use. Cooler will appear to be off in the demand system but will be supplied as long as the switch is on ("I" position). Leaving the Cooler on can eventually cause the system to turn on and off when not in use (light will turn on and off) and, over time, decrease the demand system performance.

SURGE PROTECTION

To protect components from voltage spikes in power lines, an MOV-Capacitor suppressor assembly attaches across the AC input of the rectifier bridge. The suppressor blocks spikes up to 3000V for 1 ms.

FAN MOTOR AND FAN BLADE

The smaller Cooler 10-I model contains one fan while the larger Cooler 20-I model contains two fans. All Cooler 10-I and 20-I units use the same fan blade capable of moving a large volume of air in a small area of space. Each fan blade is independently driven by a high torque, AC, small industrial fan motor. A one-time blow fuse prevents a failed fan motor from overheating and further damaging the Cooler or causing a safety problem. The fan motor is capable of operating both vertically or horizontally although vertical operation offers longer fan motor life.

PUMP AND PUMP PRESSURE

All Cooler 10-I and 20-I units contain a DC motored diaphragm pump manufactured with an integral pressure sensing control switch. The positive displacement self-priming pump consists of 3 separate, self-regulating, parallel pumping stages. If one stage fails, the other two continue pumping with a slight decrease in flow. This "soft" failure protects the water cooled gun or torch from meltdown and allows the operator to continue welding until a repair can be made. The pump's plastic design resists the common causes of water cooler pump failure such as:

- Abrasion failure due to particulate in coolant.
- Corrosion failure due to deionized water and pure glycol mixtures.
- Cavitation failure due to air bubbles introduced by an intake screen (or any other source).
- Dry operation failure due to the reservoir being emptied.
- Over pressure failure due to crimping or blocking of water hoses.
- Catastrophic sudden failure due to wear of carbon vanes in turbine pumps.

The spring actuated normally closed pressure switch is located at the top of the pump head. The springs sense a pressure buildup in the pump head and, with a buildup of pressure above the operating pressure, enable the switch which shuts off power to the fan motor and pump motor. The pressure switch allows the Cooler to run intermittently "On Demand" when connected to a water valve or solenoid only providing cooling water when it is needed. This feature saves energy, but more importantly, drastically increases pump and fan motor life. For best operation, no delay time should exist from the time flow stops and when the pump is turned off. (Refer to "Magnum System Monitor" Section).

PUMP FAILURE

Magnum Cooler pumps are designed to fail "soft" so that welding can continue until a repair is made. In the unlikely event of a "soft" pump failure, water will slowly leak from the pump head and drip out the case sides of the unit. The internal electrical components are isolated away from the pump and are in no danger from the leak. S20095-1 and S20095-3 Pump Replacement Kits and S20095-2 Pump Rebuild Kit are available for repair of the pump. The only tool required is a Phillips head screwdriver.

COOLING EFFICIENCY

The high cooling efficiency of Magnum Coolers offers a cooler, more comfortable gun or torch than conventional air cooled procedures as well as leading competitors water cooled systems. The heat exchanger's corrugated fin improves heat convection transfer while minimizing air flow restriction. This design offers a durable construction capable of withstanding impact of objects through air slots. Table 3 states the recommended use and cooling rate for 10-I and 20-I Cooler models. Refer to Figure 9 for a description of how Magnum Coolers perform.

The Magnum Cooler effectively removes the heat of the arc away from the gun or torch handle and places it into the exiting air flow at the back of the Cooler. Outside temperature can affect the cooling performance of a Magnum Cooler.

For example:

- A. COOL day (50°F, 10°C): More HEAT is transferred from the water in the heat exchanger to the air. The water is COOLER and more HEAT is transferred from the gun or torch to the water.
RESULT: THE GUN OR TORCH FEELS COOLER
- B. HOT day (100°F, 38°C): Less HEAT is transferred from the water in the heat exchanger to the air. The water is HOTTER and less HEAT is transferred from the gun or torch to the water.
RESULT: THE GUN OR TORCH FEELS HOTTER.

Unlike other water coolers that depend on bulky reservoir size, the high efficiency components of Magnum Coolers allows the reservoir size to be small. The result is a lightweight, portable unit.

FIGURE 9

Circulation of Magnum Cooler

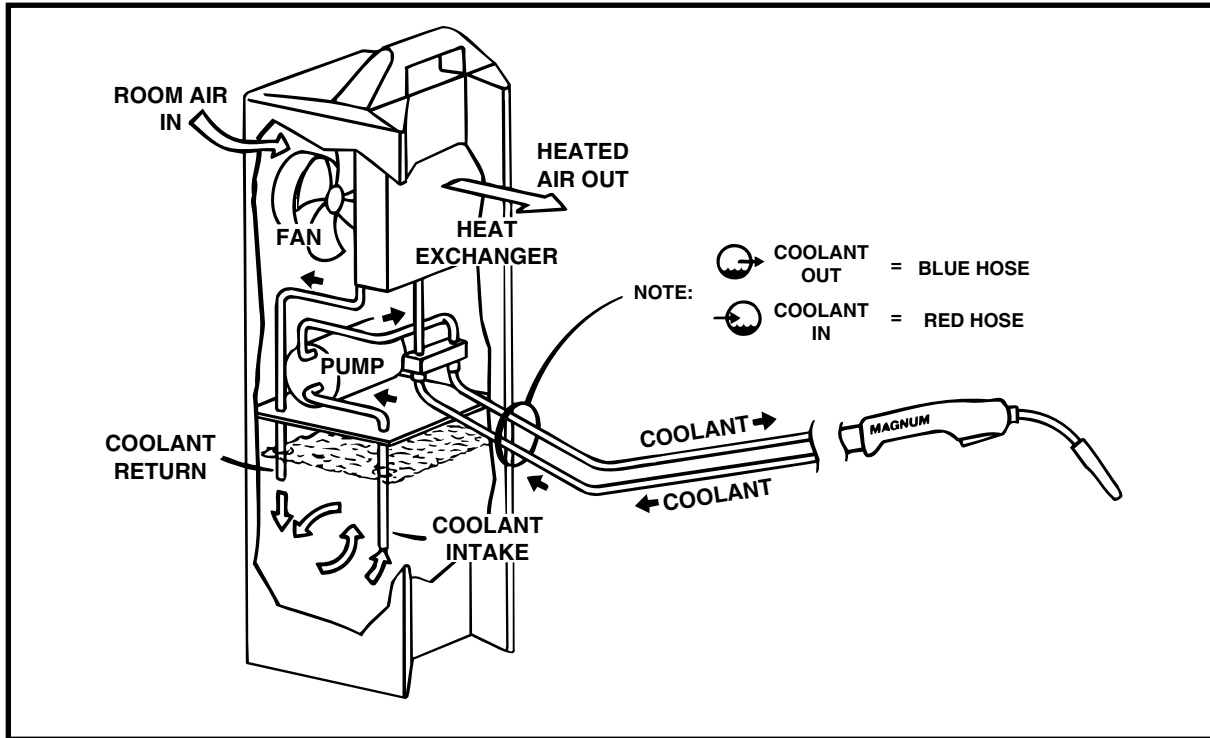

TABLE 3

Approximate Cooling Rate and Recommended Use⁽¹⁾

	Model	
	Cooler 10-I	Cooler 20-I
Product No.	K873-1	K879-1
Max. Welding Current TIG	350A 100% duty cycle	550A 100% duty cycle
Max. Welding Current MIG	350A 100% duty cycle	550A 100% duty cycle
Max. Arc Current PAW PAC Misc. Applications	Test each application for cooling requirements	

⁽¹⁾ The values listed are based on lab test results. Some applications may vary.

*PARTS DESCRIPTION FOR MAGNUM COOLER
ACCESSORIES*

***S20095-1 Pump Replacement Kit (60 psi) (4.0 bar)
(414 kPa) for Magnum Cooler 20-I Models***

Includes:

- * (1) Complete 40-60 psi (3.0-4.0 bar) (310-414 kPa) Pressure switch assembly.
- * (1) Complete 60 psi (4.0 bar) (414 kPa) Pump with all internal components and hose connections.
- * (1) Drive assembly
- (1) Installation instructions
- * All of the above assembled together with three short screws and retaining hex nuts.

***S20095-2 Pump Rebuild Kit for Magnum Cooler
10-I and 20-I Models***

Includes:

- (1) Teflon shim
- (1) Diaphragm
- (2) 45 psi (3.0 bar) (310 kPa) spring
- (1) 60 psi (4.0 bar) (414 kPa) spring
- (1) 80 psi (5.4 bar) (551 kPa) spring
- (3) Conical spring seats
- (1) Installation instructions

***S20095-3 Pump Replacement Kit (45 psi) (3.0 bar)
(310 kPa) for Magnum Cooler 10-I Models***

Includes:

- * (1) Complete 40-60 psi (3.0-4.0 bar) (310-414 kPa) Pressure switch assembly.
- * (1) Complete 45 psi (3.0 bar) (310 kPa) Pump with all internal components and hose connections.
- * (1) Drive assembly
- (1) Installation instructions
- * All of the above assembled together with three short screws and retaining hex nuts.

⚠ WARNING**ELECTRIC SHOCK** can kill.

- Disconnect input power by removing plug from receptacle before working inside Cooler.
- Do not operate with covers removed.
- Use only grounded receptacle.
- Do not remove the power cord ground prong.
- Do not touch electrically "hot" parts inside Cooler.
- Have qualified personnel do the installation, maintenance and troubleshooting work.

Both the S20095-1 and S20095-3 Pump Replacement Kits consist of a molded pump head equipped with all internal pump components to replace a failed pump or cracked pump head of a Magnum Cooler. The Pump Replacement Kit includes a complete pre-assembled pressure switch assembly and pump assembly. Although the Pump Replacement Kit costs more than the Pump Rebuild Kit, the time to install it is less and saves money when down time is costly. When repairing the Cooler pump, follow the instructions supplied with the kit. The only tool needed for installing the S20095-1 or S20095-3 Pump Replacement Kit is a Phillips head screw driver. Reference Parts Section for a parts list of the Pump Replacement Kit.

S20095-2 Pump Rebuild Kit for Magnum Cooler 10-I and 20-I Units:

The S20095-2 Rebuild Kit consists of all the necessary internal components to rebuild the most common "soft" pump failure that occurs in a Magnum Cooler. Water will slowly drip from the pump head when the pump experiences a "soft" failure. The rebuild procedure is more involved than the pump replacement procedure but is more cost efficient when labor rates are low or when down time is not critical. The only tool needed for rebuilding the pump is a Phillips head screw driver. Follow the instructions supplied with the kit when rebuilding the pump head. Reference Parts Section for the S20095-2 Magnum Cooler Pump Rebuild Kit.

HEAT EXCHANGER MAINTENANCE

To maintain maximum efficiency, the heat exchanger should be kept clean from dust and dirt buildup. Clean the heat exchanger periodically using a vacuum hose or low pressure air line. Avoid placing the unit near a flux hopper or a flux waste container. A clean heat exchanger offers better cooling performance and longer product life. If extremely dirty conditions exist, it may be necessary to remove the heat exchanger completely from the Cooler for a thorough soap and water cleaning of the cooling fins. Use care to avoid damaging the fins.

RESERVOIR MAINTENANCE

The reservoir volume should be checked daily before using the Cooler. Remove the reservoir fill cap and check the coolant level. Unit is full when the coolant lies just below the reservoir fill opening with the unit in an upright position. Keep the reservoir full especially after changing the water lines.

The Cooler should always be operated with the reservoir fill cap on. In areas where dust can be introduced into the reservoir through water lines or reservoir fill cap removal, periodically flush the unit out. Dump the old coolant and rinse the inside of the reservoir. Add new coolant when finished. A reservoir free from particle buildup and dirt offers better cooling efficiency and longer pump, gun and torch life.

S20095-1 Pump Replacement Kit (60 psi) for Magnum Cooler 20-I Units:

S20095-3 Pump Replacement Kit (45 psi) for Magnum Cooler 10-I Units:

TROUBLESHOOTING GUIDE

WARNING



ELECTRIC SHOCK can kill.

- Do not touch electrically live parts such as internal wiring.
- Turn OFF input power at welding power source and accessory power source before installation or service.
- Cooler must be connected to system ground per any National Electrical Code or any applicable local codes.
- Only qualified personnel should perform installation or service.

Observe all additional Safety Guidelines detailed throughout this manual.

WARNING

This Troubleshooting Guide is designed to be used by the machine Owner/Operator. Unauthorized repairs performed on this equipment may result in danger to the technician and machine operator and will invalidate your factory warranty. For your safety, please observe all safety notes and precautions detailed in the Safety Section of this manual to avoid electrical shock or danger while troubleshooting this equipment.

CAUTION

If for any reason you do not understand the test procedures or are unable to perform the tests/repairs safely, contact your local Authorized Field Service Facility for technical troubleshooting assistance before you proceed.

Observe all Safety Guidelines detailed throughout this manual

PROBLEMS (SYMPTOMS)	POSSIBLE AREAS OF MISADJUSTMENTS(S)	RECOMMENDED COURSE OF ACTION
Cooler does not operate with power switch on. (Switch pushed to "1" position.)	<ul style="list-style-type: none"> a. Power cord unplugged. b. No power at outlet. c. Power cordset damaged. d. Unit too hot. Thermal protector tripped. e. Water lines blocked or crimped. f. Unit is used in a demand system and water valve or solenoid damaged. g. Leak in gun or water hoses. h. Reservoir empty. i. Power switch faulty. j. Solenoid valve is closed. k. Female quick-connect fittings are not connected to male fittings. 	<ul style="list-style-type: none"> a. Plug in power cord. b. Check outlet circuit breaker. c. Repair damaged cord or order new cordset. d. Allow unit to cool. Relocate unit away from source of heat. e. Clear blockage in hose. Avoid kinking or putting sharp bends in water lines. f. Repair water valve or solenoid. g. Repair leak. h. Fill reservoir. i. Replace power switch. j. Pull trigger on welding gun to open solenoid valve. k. Connect all quick connect fittings to their mating parts.
Power switch blinks or flickers while coolant is flowing. (Continuous use, NO Water Valve or Solenoid in the system.)	<ul style="list-style-type: none"> a. Water lines partially blocked or obstructed. b. Internal hose or heat exchanger is blocked. c. Restriction is too high for the Cooler being used. 	<ul style="list-style-type: none"> a. Clear blockage in hose. Avoid kinking or putting sharp bends in water lines. b. Carefully clear blockage. Clean all hoses and the reservoir. c. Use the Cooler 20-I for MIG applications. Cooler 10-I can be used for either MIG or TIG applications.
Using a water valve or solenoid and power switch blinks or flickers while coolant is flowing or when flow is stopped.	<ul style="list-style-type: none"> a. Water lines partially blocked or obstructed. b. Water valve or solenoid failure. c. Internal hose or heat exchanger is blocked. d. Restriction is too high for the Cooler being used. 	<ul style="list-style-type: none"> a. Clear blockage in hose. Avoid kinking or putting sharp bends in water lines. b. Repair or replace water valve or solenoid. c. Carefully clear blockage. Clean all hoses and the reservoir. d. Use the Cooler 20-I for MIG applications. Cooler 10-I can be used for either MIG or TIG applications.
Using water valve or solenoid and power switch light turns on and off when not in use.	<ul style="list-style-type: none"> a. Leak in gun or water hoses. b. Demand system stress. System not used for long period of time with Cooler left on. (Power switch pushed to "1"). 	<ul style="list-style-type: none"> a. Repair leak. b. Turn power switch off when not in use. (Power switch pushed to "O"). DO NOT LEAVE POWER ON WHEN COOLER IS NOT IN USE FOR A LONG PERIOD OF TIME.
Internal water leak.	<ul style="list-style-type: none"> a. Hose clamp loose on one of internal hoses. b. Internal hose punctured. c. Heat exchanger leaking. d. Pump experiencing "soft" failure and leaking around plastic housing of pump head. e. Pump head cracked. 	<ul style="list-style-type: none"> a. Tighten or replace hose clamp. b. Replace punctured hose with new hose. c. Replace heat exchanger. d. Repair pump with S20095-1 or S20095-3 Pump Replacement Kit or S20095-2 Pump Rebuild Kit. e. Replace pump head with S20095-1 or S20095-3 Pump Replacement Kit.

Observe all Safety Guidelines detailed throughout this manual

PROBLEMS (SYMPTOMS)	POSSIBLE AREAS OF MISADJUSTMENTS(S)	RECOMMENDED COURSE OF ACTION
Leak at inlet/outlet connector block.	<ul style="list-style-type: none"> a. Loose connector fitting. b. Hose clamp loose. 	<ul style="list-style-type: none"> a. Tighten connector nut. (5/8-18 left hand thread). b. Tighten hose clamp onto hose.
Torch or gun runs hot.	<ul style="list-style-type: none"> a. Unit placed by area of extreme heat. b. Low coolant flow. c. No coolant flow. d. Fan not operating. e. Heat exchanger clogged. 	<ul style="list-style-type: none"> a. Move unit away from hot air. b. See Low Coolant Flow Section. c. See No Coolant Flow Section. d. Reference fan section. e. Clean heat exchanger.
Fan operates but there is low coolant flow.	<ul style="list-style-type: none"> a. Leak in torch/gun or hoses. b. Torch/gun or hoses partially obstructed. c. Reservoir empty or very low. d. DC+ or DC- connection loose on rectifier bridge. e. Pressure low (pump motor failing). f. One or more pump stages have failed. 	<ul style="list-style-type: none"> a. Repair leak. b. Clear obstruction. c. Refill reservoir. d. Secure DC+ or DC- connectors on rectifier bridge. e. Replace pump motor. f. Repair the pump with S20095-1 or S20095-3 Pump Replacement Kit or S20095-2 Pump Rebuild Kit.
Fan operates but there is no coolant flow.	<ul style="list-style-type: none"> a. Pump motor failure. b. Pump head seized (bearing failure). 	<ul style="list-style-type: none"> a. Replace pump motor. b. Replace pump head with S20095-1 or S20095-3 Pump Replacement Kit.

 **CAUTION**

If for any reason you do not understand the test procedures or are unable to perform the tests/repairs safely, contact your **Local Lincoln Authorized Field Service Facility** for technical troubleshooting assistance before you proceed.

MAGNUM COOLER 10-I & 20-I



Observe all Safety Guidelines detailed throughout this manual

PROBLEMS (SYMPTOMS)	POSSIBLE AREAS OF MISADJUSTMENTS(S)	RECOMMENDED COURSE OF ACTION
Pump operates, but fan does not.	<ul style="list-style-type: none"> a. Internal AC circuit open. b. Fan blade contacting heat exchanger. c. Fan motor failure 	<ul style="list-style-type: none"> a. Secure AC connectors on rectifier bridge. b. If fan blades are plastic, replace. Reset fan clearance and secure fan to motor shaft. c. Replace fan motor with Fan Motor and Mount Assembly.
Cooler trips outlet circuit breaker.	<ul style="list-style-type: none"> a. Circuit overloaded. b. Cooler electrical component failure. 	<ul style="list-style-type: none"> a. Check outlet circuit breaker. b. Replace suppressor assembly and rectifier bridge inside of Cooler.

⚠ CAUTION

If for any reason you do not understand the test procedures or are unable to perform the tests/repairs safely, contact your **Local Lincoln Authorized Field Service Facility** for technical troubleshooting assistance before you proceed.

MAGNUM COOLER 10-I & 20-I



MAGNUM COOLERS CODES 10266 THRU 10269

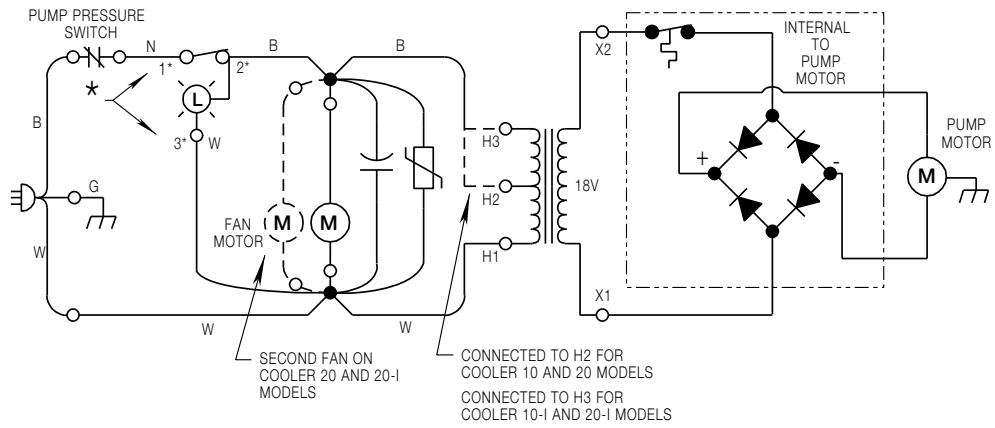

* NUMBERS EMBOSSED ON SWITCH HOUSING
ELECTRICAL SYMBOLS PER E1537
COLOR CODE:
B - BLACK N - BROWN
W - WHITE
G - GREEN

INPUT:	COOLER 10	115 V	COOLER 10-I	220 V
	AND		AND	
	COOLER 20	60 Hz	COOLER 20-I	50/60 Hz

A

S22534

MAGNUM COOLERS CODES 9743 THRU 9746

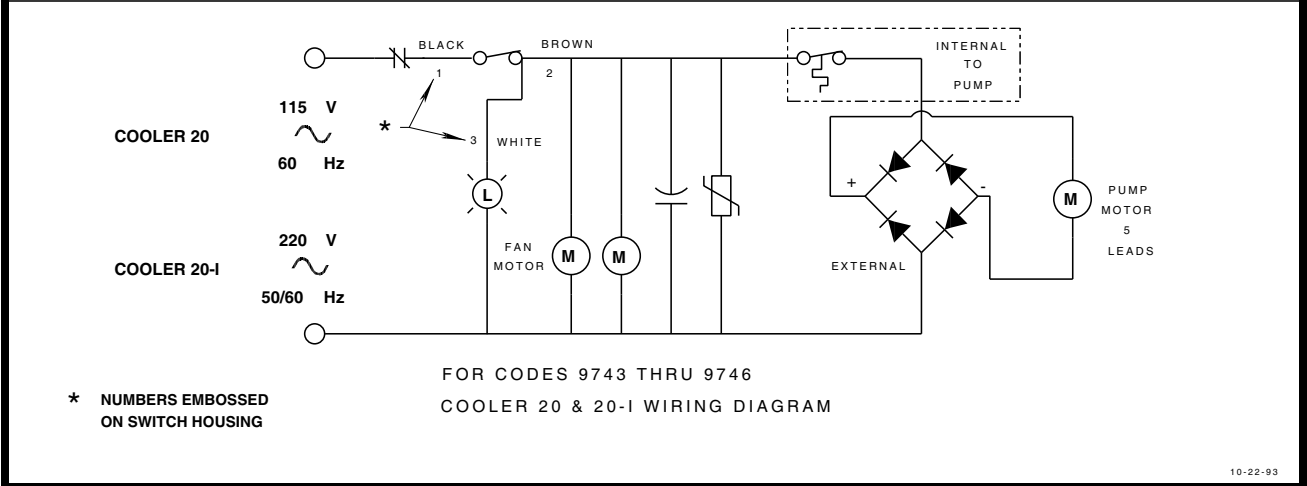
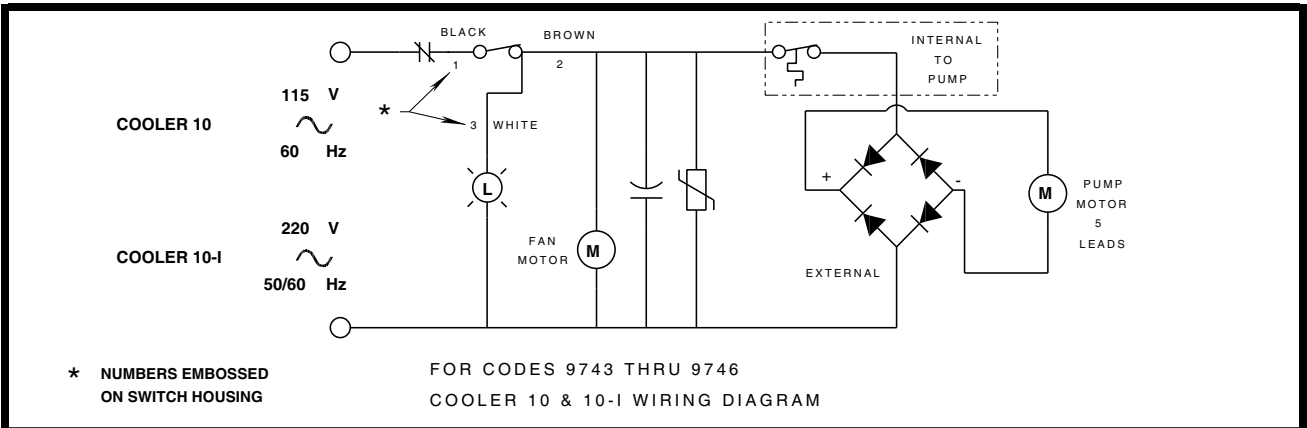

10-22-93

S20690

MAGNUM COOLERS CODES 9984 THRU 9987

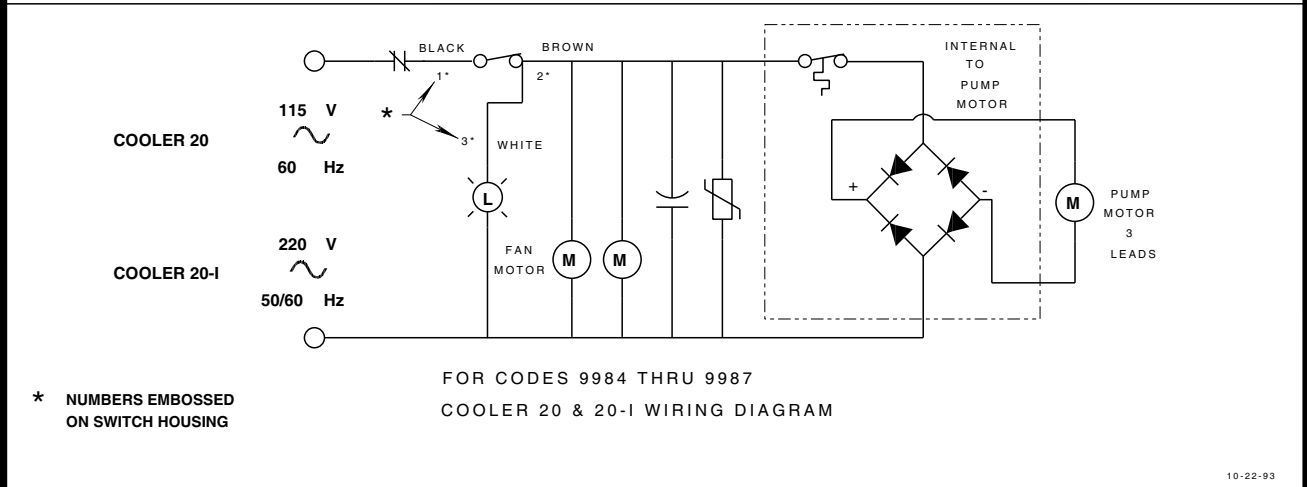
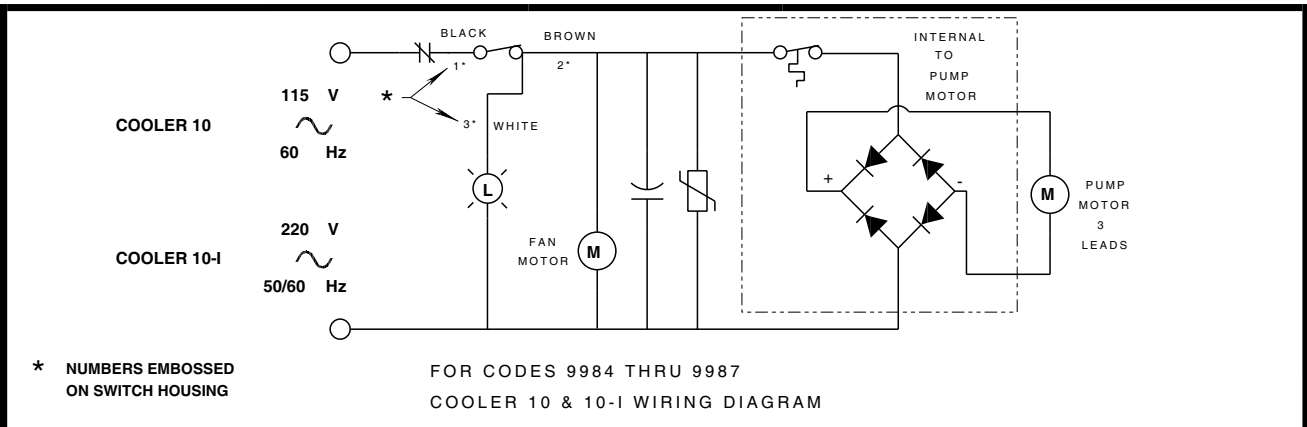

10-22-93

S20691

WARNING	<ul style="list-style-type: none"> ● Do not touch electrically live parts or electrode with skin or wet clothing. ● Insulate yourself from work and ground. 	<ul style="list-style-type: none"> ● Keep flammable materials away. 	<ul style="list-style-type: none"> ● Wear eye, ear and body protection.
Spanish AVISO DE PRECAUCION	<ul style="list-style-type: none"> ● No toque las partes o los electrodos bajo carga con la piel o ropa mojada. ● Aíslese del trabajo y de la tierra. 	<ul style="list-style-type: none"> ● Mantenga el material combustible fuera del área de trabajo. 	<ul style="list-style-type: none"> ● Protéjase los ojos, los oídos y el cuerpo.
French ATTENTION	<ul style="list-style-type: none"> ● Ne laissez ni la peau ni des vêtements mouillés entrer en contact avec des pièces sous tension. ● Isolez-vous du travail et de la terre. 	<ul style="list-style-type: none"> ● Gardez à l'écart de tout matériel inflammable. 	<ul style="list-style-type: none"> ● Protégez vos yeux, vos oreilles et votre corps.
German WARNUNG	<ul style="list-style-type: none"> ● Berühren Sie keine stromführenden Teile oder Elektroden mit Ihrem Körper oder feuchter Kleidung! ● Isolieren Sie sich von den Elektroden und dem Erdboden! 	<ul style="list-style-type: none"> ● Entfernen Sie brennbares Material! 	<ul style="list-style-type: none"> ● Tragen Sie Augen-, Ohren- und Körperschutz!
Portuguese ATENÇÃO	<ul style="list-style-type: none"> ● Não toque partes elétricas e electrodos com a pele ou roupa molhada. ● Isole-se da peça e terra. 	<ul style="list-style-type: none"> ● Mantenha inflamáveis bem guardados. 	<ul style="list-style-type: none"> ● Use proteção para a vista, ouvido e corpo.
Japanese 注意事項	<ul style="list-style-type: none"> ● 通電中の電気部品、又は溶材にヒフやぬれた布で触れないこと。 ● 施工物やアースから身体が絶縁されている様にして下さい。 	<ul style="list-style-type: none"> ● 燃えやすいものの側での溶接作業は絶対にしてはなりません。 	<ul style="list-style-type: none"> ● 目、耳及び身体に保護具をして下さい。
Chinese 警告	<ul style="list-style-type: none"> ● 皮膚或濕衣物切勿接觸帶電部件及鎢條。 ● 使你自已與地面和工件絕緣。 	<ul style="list-style-type: none"> ● 把一切易燃物品移離工作場所。 	<ul style="list-style-type: none"> ● 佩戴眼、耳及身體勞動保護用具。
Korean 위험	<ul style="list-style-type: none"> ● 전도체나 용접봉을 젖은 형갑 또는 피부로 절대 접촉치 마십시오. ● 모재와 접지를 접촉치 마십시오. 	<ul style="list-style-type: none"> ● 인화성 물질을 접근시키지 마십시오. 	<ul style="list-style-type: none"> ● 눈, 귀와 몸에 보호장구를 착용하십시오.
Arabic تحذير	<ul style="list-style-type: none"> ● لا تلمس الاجزاء التي يسري فيها التيار الكهربائي أو الألكترود بجسدك أو بالملابس المبللة بالماء. ● ضع عازلا على جسمك خلال العمل. 	<ul style="list-style-type: none"> ● ضع المواد القابلة للاشتعال في مكان بعيد. 	<ul style="list-style-type: none"> ● ضع أدوات وملابس واقية على عينيك وأذنيك وجسمك.

READ AND UNDERSTAND THE MANUFACTURER'S INSTRUCTION FOR THIS EQUIPMENT AND THE CONSUMABLES TO BE USED AND FOLLOW YOUR EMPLOYER'S SAFETY PRACTICES.

SE RECOMIENDA LEER Y ENTENDER LAS INSTRUCCIONES DEL FABRICANTE PARA EL USO DE ESTE EQUIPO Y LOS CONSUMIBLES QUE VA A UTILIZAR, SIGA LAS MEDIDAS DE SEGURIDAD DE SU SUPERVISOR.

LISEZ ET COMPRENEZ LES INSTRUCTIONS DU FABRICANT EN CE QUI REGARDE CET EQUIPMENT ET LES PRODUITS A ETRE EMPLOYES ET SUIVEZ LES PROCEDURES DE SECURITE DE VOTRE EMPLOYEUR.

LESEN SIE UND BEFOLGEN SIE DIE BETRIEBSANLEITUNG DER ANLAGE UND DEN ELEKTRODENEINSATZ DES HERSTELLERS. DIE UNFALLVERHÜTUNGSVORSCHRIFTEN DES ARBEITGEBERS SIND EBENFALLS ZU BEACHTEN.

			
<ul style="list-style-type: none"> ● Keep your head out of fumes. ● Use ventilation or exhaust to remove fumes from breathing zone. 	<ul style="list-style-type: none"> ● Turn power off before servicing. 	<ul style="list-style-type: none"> ● Do not operate with panel open or guards off. 	WARNING
<ul style="list-style-type: none"> ● Los humos fuera de la zona de respiración. ● Mantenga la cabeza fuera de los humos. Utilice ventilación o aspiración para gases. 	<ul style="list-style-type: none"> ● Desconectar el cable de alimentación de poder de la máquina antes de iniciar cualquier servicio. 	<ul style="list-style-type: none"> ● No operar con panel abierto o guardas quitadas. 	Spanish AVISO DE PRECAUCION
<ul style="list-style-type: none"> ● Gardez la tête à l'écart des fumées. ● Utilisez un ventilateur ou un aspirateur pour ôter les fumées des zones de travail. 	<ul style="list-style-type: none"> ● Débranchez le courant avant l'entretien. 	<ul style="list-style-type: none"> ● N'opérez pas avec les panneaux ouverts ou avec les dispositifs de protection enlevés. 	French ATTENTION
<ul style="list-style-type: none"> ● Vermeiden Sie das Einatmen von Schweißrauch! ● Sorgen Sie für gute Be- und Entlüftung des Arbeitsplatzes! 	<ul style="list-style-type: none"> ● Strom vor Wartungsarbeiten abschalten! (Netzstrom völlig öffnen; Maschine anhalten!) 	<ul style="list-style-type: none"> ● Anlage nie ohne Schutzgehäuse oder Innenschutzverkleidung in Betrieb setzen! 	German WARNUNG
<ul style="list-style-type: none"> ● Mantenha seu rosto da fumaça. ● Use ventilação e exaustão para remover fumo da zona respiratória. 	<ul style="list-style-type: none"> ● Não opere com as tampas removidas. ● Desligue a corrente antes de fazer serviço. ● Não toque as partes elétricas nuas. 	<ul style="list-style-type: none"> ● Mantenha-se afastado das partes moventes. ● Não opere com os painéis abertos ou guardas removidas. 	Portuguese ATENÇÃO
<ul style="list-style-type: none"> ● ヒュームから頭を離すようにして下さい。 ● 換気や排煙に十分留意して下さい。 	<ul style="list-style-type: none"> ● メンテナンス・サービスに取りかかる際には、まず電源スイッチを必ず切ってください。 	<ul style="list-style-type: none"> ● パネルやカバーを取り外したまま機械操作をしないで下さい。 	Japanese 注意事項
<ul style="list-style-type: none"> ● 頭部遠離煙霧。 ● 在呼吸區使用通風或排風器除煙。 	<ul style="list-style-type: none"> ● 維修前切斷電源。 	<ul style="list-style-type: none"> ● 儀表板打開或沒有安全罩時不準作業。 	Chinese 警告
<ul style="list-style-type: none"> ● 얼굴로부터 용접가스를 멀리하십시오. ● 호흡지역으로부터 용접가스를 제거하기 위해 가스제거기나 통풍기를 사용하십시오. 	<ul style="list-style-type: none"> ● 보수전에 전원을 차단하십시오. 	<ul style="list-style-type: none"> ● 판넬이 열린 상태로 작동치 마십시오. 	Korean 위험
<ul style="list-style-type: none"> ● ابعد رأسك بعيداً عن الدخان. ● استعمل التهوية أو جهاز ضغط الدخان للخارج لكي تبعد الدخان عن المنطقة التي تتنفس فيها. 	<ul style="list-style-type: none"> ● أقطع التيار الكهربائي قبل القيام بأية صيانة. 	<ul style="list-style-type: none"> ● لا تشغيل هذا الجهاز اذا كانت الاغطية الحديدية الواقية ليست عليه. 	Arabic تحذير

LEIA E COMPREENDA AS INSTRUÇÕES DO FABRICANTE PARA ESTE EQUIPAMENTO E AS PARTES DE USO, E SIGA AS PRÁTICAS DE SEGURANÇA DO EMPREGADOR.

使う機械や溶材のメーカーの指示書をよく読み、まず理解して下さい。そして貴社の安全規定に従って下さい。

請詳細閱讀並理解製造廠提供的說明以及應該使用的銀焊材料，並請遵守貴方的有閣勞動保護規定。

이 제품에 동봉된 작업지침서를 숙지하시고 귀사의 작업자 안전수칙을 준수하시기 바랍니다.

اقرأ بتمعن وافهم تعليمات المصنع المنتج لهذه المعدات والمواد قبل استعمالها واتبع تعليمات الوقاية لصاحب العمل.